

DUCTILE IRON MECHANICAL JOINT CONNECTOR

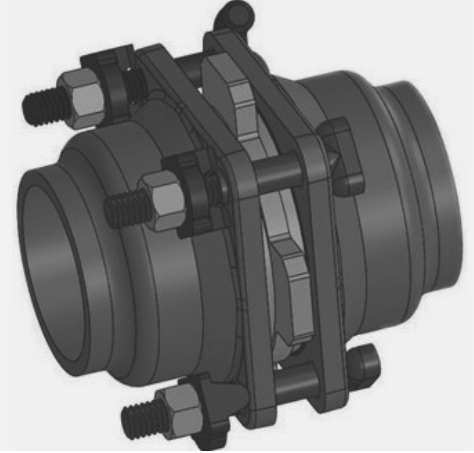
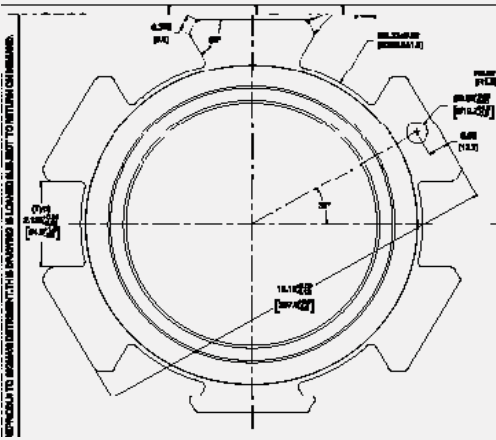

PRODUCT SPECIFICATIONS

- SIZE RANGE:**
- 3"-36"
- MATERIAL:**
- MJ x MJ Connector and T-Head Spacers manufactured from high strength ductile iron in accordance with ASTM A536 Grade 65-45-12.
- PRESSURE RATING:**
- 350 PSI Water Working Pressure 3" - 24"
 - 250 PSI Water Working Pressure 30" & 36"
- TESTING:**
- Manufactured in accordance with ANSI/AWWA C153/A21.53 and ANSI/AWWA C110/A210.10.
 - All fittings are hydrostatically tested in accordance with SIGMA Quality Management Standard.
 - All fittings are heat coded to ensure traceability and verification of metallurgical properties in accordance with the prevailing standards and SIGMA Quality Management Standards.
- COATING:**
- Inside & Outside of MJ Connector and T-Head Spacer are e-coated.
- GASKETS:**
- SBR in accordance with ANSI/AWWA C111/A21.11
 - Other rubber material - EPDM, Nitrile, Neoprene, FKM are available.
- T-BOLTS:**
- Low Alloy corrosion resistant high strength steel in accordance with ANSI/AWWA C111/A21.11
 - Other material - HSLA Steel with Corblue coating, SS304, SS316 are available.
- EYE-BOLTS:**
- Low Alloy corrosion resistant high strength steel in accordance with ANSI/AWWA C111/A21.11.
 - Other material - HSLA Steel with Corblue coating, SS304, SS316 are available.
- STANDARDS:**
- Certified to NSF61 Standard.
 - ANSI/AWWA C153/A21.53 Ductile Iron Compact Fittings
- INSTALLATION:**
- Per ANSI/AWWA C600 Standard Installation of Ductile-Iron Mains and Their Appurtenances

SIGMA MJ CONNECTOR

Features & Advantages:

Sizes 3 - 36"

- The SIGMA MJ Connector is a simple, light weight product that provides restraint between MJ Valves and MJ Fittings.
- Its Compact design provides a bolt through restraint option between two MJ Bells when space is limited
- No Pipe to saw or Pipe damage since no pipe connection is required
- Comes complete with all necessary accessories
- Close-coupled connections allow you to pre-assemble before transporting to the job site
- Two MJ's are connected using one accessory kit, instead of the standard two, allowing less chance for leakage

Sample Specification:

The MJ x MJ Connector will incorporate a bolt-through restraint mechanism design that allows for connection of MJ x MJ bells of valves and fittings with T-head bolts and Eye bolts. The MJ x MJ Connector and spacers shall be manufactured from high strength ductile iron in accordance with ASTM A536, Grade 65-45-12 and supplied with standard NSF-61 Approved asphaltic seal coat that conforms to ANSI/AWWA C104/A21.4. The MJ x MJ Connector kit shall come complete with one MJ x MJ connector, two standard SBR (Styrene Butadiene Rubber) mechanical joint gaskets, and all required T-head bolts and Eye bolts.

The SIGMA MJ Connector meets the working pressure specifications of ANSI/AWWA C153/ A21.53 Ductile-Iron Compact Fittings and ANSI/AWWA C110/A21.10 Ductile-Iron and Gray-Iron Fittings. The MJ x MJ Connector shall have a maximum water working pressure of 350 PSI for sizes 3" - 24" and 250 PSI for sizes 30" & 36" for use with standard Mechanical Joint fittings and valves.

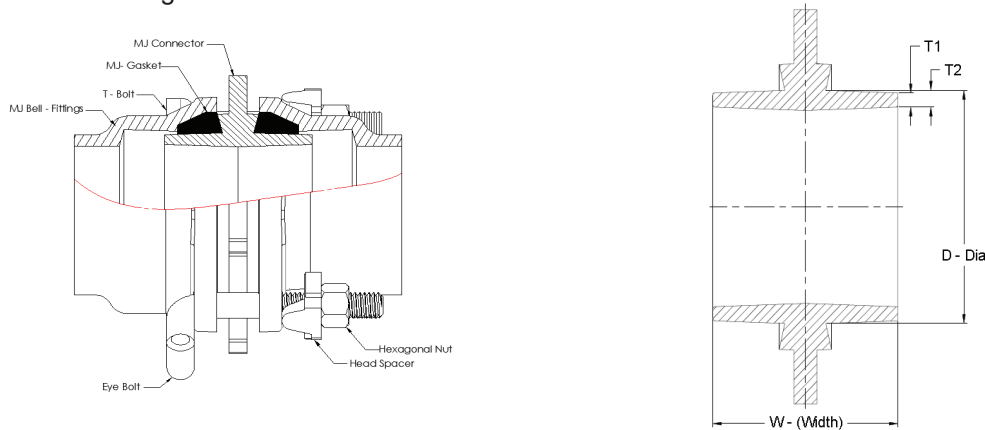

Dimensions in Inches, Weights in Pounds

C153 MJ Connector E-coat w/accessory kit												
Size	Item #	MJ Gasket	T-Head Bolt (Qty)	Eye Bolt (Qty)	Eye Bolt Dim	Head Spacer	Width (Inch)	Diameter (OD-Inch)	T - 1 (Inch)	T - 2 (Inch)	Casting Weight (lbs)	Weight (lbs) w/accessories
3	DMCPEP3	2	4	N/A	N/A	4	4.00	3.96	0.28	0.33	6.70	11.33
4	DMCPEP4	2	4	N/A	N/A	4	4.00	4.80	0.29	0.34	8.2	14.82
6	DMCPEP6	2	4	2	3/4" X 4-1/2"	6	4.00	6.90	0.31	0.36	15.4	24.98
8	DMCPEP8	2	4	2	3/4"X5"	6	4.00	9.05	0.33	0.38	18	28.17
10	DMCPEP10	2	4	4	3/4"X5"	8	4.00	11.10	0.35	0.40	30.4	43.59
12	DMCPEP12	2	4	4	3/4" X 5-1/2"	8	4.50	13.20	0.36	0.42	31.2	45.35
14	DMCPEP14	2	10	N/A	N/A	10	6.00	15.30	0.40	0.47	54.93	71.49
16	DMCPEP16	2	12	N/A	N/A	12	6.80	17.40	0.33	0.45	64.27	83.81
18	DMCPEP18	2	12	N/A	N/A	12	6.80	19.50	0.42	0.54	84.18	104.66
20	DMCPEP20	2	14	N/A	N/A	14	6.80	21.60	0.41	0.53	85.25	108.22
24	DMCPEP24	2	16	N/A	N/A	16	6.80	25.80	0.45	0.61	107.05	134.21
30	DMCPEP30	2	20	N/A	N/A	20	7.50	32.00	0.62	0.75	144.36	202.47
36	DMCPEP36	2	24	N/A	N/A	24	7.50	38.30	0.69	0.82	181.83	253.76

Note: Accessories include MJ Gasket, T-Head Bolt, Eye-Bolt and Head Spacer

MJ Connector Accessories Details

C153 Accessories Pack:

C153 Accessories Pack										
Size	SIGMA Part #	SIGMA Item Description	Adapter	MJ Gasket	T-Bolt & Nut			Eyebolt		Spacer
			Qty	Qty	Part #	Size	Qty	Dims	Qty	Qty
3	DMCPEP3	3 C153 MJ CONNECTOR PIECE	1	2	TB40N58	5/8" x 4"	4	N/A	N/A	4
4	DMCPEP4	4 C153 MJ CONNECTOR PIECE	1	2	TB50	3/4" x 5"	4	N/A	N/A	4
6	DMCPEP6	6 C153 MJ CONNECTOR PIECE	1	2	TB50	3/4" x 5"	4	3/4" x 5"	2	6
8	DMCPEP8	8 C153 MJ CONNECTOR PIECE	1	2	TB50	3/4" x 5"	4	3/4"X5"	2	6
10	DMCPEP10	10 C153 MJ CONNECTOR PIECE	1	2	TB50	3/4" x 5"	4	3/4"X5"	4	8
12	DMCPEP12	12 C153 MJ CONNECTOR PIECE	1	2	TB55	3/4" x 5 1/2"	4	3/4" X 5-1/2"	4	8
14	DMCPEP14	14 C153 MJ CONNECTOR PIECE	1	2	TB55	3/4" x 5 1/2"	10	N/A	N/A	10
16	DMCPEP16	16 C153 MJ CONNECTOR PIECE	1	2	TB63	3/4" x 6"	12	N/A	N/A	12
18	DMCPEP18	18 C153 MJ CONNECTOR PIECE	1	2	TB63	3/4" x 6"	12	N/A	N/A	12
20	DMCPEP20	20 C153 MJ CONNECTOR PIECE	1	2	TB63	3/4" x 6"	14	N/A	N/A	14
24	DMCPEP24	24 C153 MJ CONNECTOR PIECE	1	2	TB70	3/4" x 7"	16	N/A	N/A	16
30	DMCPEP30	30 C153 MJ CONNECTOR PIECE	1	2	TB75	1" x 7 1/2"	20	N/A	N/A	20
36	DMCPEP36	36 C153 MJ CONNECTOR PIECE	1	2	TB75	1" x 7 1/2"	24	N/A	N/A	24

C110 Accessories Pack: Call your local SIGMA Representative

C110 Accessories Pack										
Size	SIGMA Part #	SIGMA Item Description	Adapter	MJ Gasket	T-Bolt & Nut			Eyebolt		Spacer
			Qty	Qty	Part #	Size	Qty	Dims	Qty	Qty
3	DMCPEP3	3 C153 MJ CONNECTOR PIECE	1	2	TB40N58	5/8" x 5"	4	N/A	N/A	4
4	DMCPEP4	4 C153 MJ CONNECTOR PIECE	1	2	TB55	3/4" x 5 1/2"	4	N/A	N/A	4
6	DMCPEP6	6 C153 MJ CONNECTOR PIECE	1	2	TB55	3/4" x 5 1/2"	4	3/4" x 5 1/2"	2	6
8	DMCPEP8	8 C153 MJ CONNECTOR PIECE	1	2	TB55	3/4" x 5 1/2"	4	3/4" x 5 1/2"	2	6
10	DMCPEP10	10 C153 MJ CONNECTOR PIECE	1	2	TB55	3/4" x 5 1/2"	4	3/4" x 5 1/2"	4	8
12	DMCPEP12	12 C153 MJ CONNECTOR PIECE	1	2	TB60N34	3/4" x 6"	4	3/4" x 6"	4	8
14	DMCPEP14	14 C153 MJ CONNECTOR PIECE	1	2	TB70	3/4" x 7"	10	N/A	N/A	10
16	DMCPEP16	16 C153 MJ CONNECTOR PIECE	1	2	TB70	3/4" x 7"	12	N/A	N/A	12
18	DMCPEP18	18 C153 MJ CONNECTOR PIECE	1	2	TB75N34	3/4" x 7 1/2"	12	N/A	N/A	12
20	DMCPEP20	20 C153 MJ CONNECTOR PIECE	1	2	TB75N34	3/4" x 7 1/2"	14	N/A	N/A	14
24	DMCPEP24	24 C153 MJ CONNECTOR PIECE	1	2	TB75N34	3/4" x 7 1/2"	16	N/A	N/A	16
30	DMCPEP30	30 C153 MJ CONNECTOR PIECE	1	2	TB90N100	1" x 9"	20	N/A	N/A	20
36	DMCPEP36	36 C153 MJ CONNECTOR PIECE	1	2	TB90N100	1" x 9"	24	N/A	N/A	24

NOTE: MJ Connector Adapter is now offered with Stainless Steel and Fluoro Blue accessories. Please contact your SIGMA representative for details and availability.

SIGMA MJ CONNECTOR

INSTALLATION INSTRUCTION FOR MJ VALVE AND FITTING RESTRAINT

BEFORE YOU BEGIN: Match the Accessory Pak to the fittings being installed.

- 1) For typical C153 compact fittings and valves STANDARD Accessory Pak
- 2) LONG-BOLT Accessory Pak - for full-body C110 fittings and certain butterfly valves with thick bolt flanges

HYDRANT AND OTHER CONNECTIONS

- When connecting both the “branch” and “run” of 3 thru 14 inch compact tees or crosses, or 6 and 8 inch 90s the standard accessory bolts may interfere with each other. Substituting shorter bolts should solve this. Conduct a trial connection prior to assembly in the field. Special accessory paks with shorter bolts are available. Contact SIGMA for more info.
- We highly recommend that when hydrants are being connected a trial connection is made prior to field assembly due to the large variety of hydrant designs available. Connector can be assembled on many hydrant shoes that have adequate space for bolt clearance.

WRENCH SIZES

A combination wrench may be required to install the Connector on some valves. Wrench size required:

- 3-inch (75mm): 1 1/16-inch wrench
- 4 to 12-in (100-300mm): 1 1/8-inch wrench
- 14 to 24-inch (350-600mm): 1 1/4-inch wrench
- 30 to 36-inch (750-900mm): 1 5/8-inch wrench

1

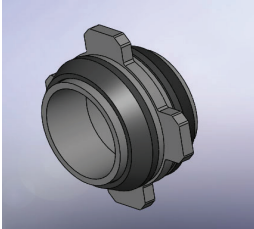

a) Be sure to lubricate both the INSIDE and OUTSIDE of gaskets.

b) Fully seat gasket on each side of the MJ Connector.

2

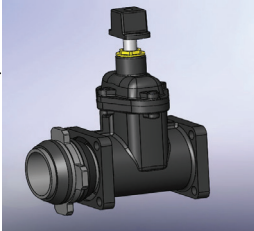

a) If possible, place valve or fitting on its end and push MJ Connector into it.

b) Install EVENLY.

3

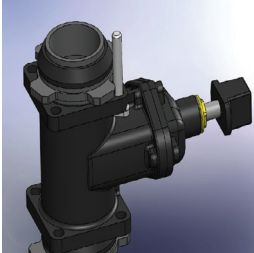

a) Install T-bolts first. This provides easier eyebolt installation. Put bolts in hard-to-reach holes BEFORE placing the fitting into position.

b) EVENLY seat fitting on the MJ Connector and install the remaining bolts.

4

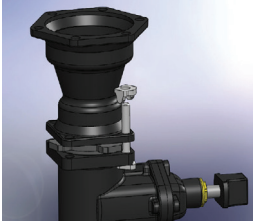

a) Place T-head spacers on bolts with the rounded side against the flange of the fitting or valve so the nut is against the flat side.

5

Diameter, inches	Diameter, mm	NUMBER OF EYEBOLTS
3, 4	75, 100	none
6, 8	150, 200	1 eye-bolt on each side of valve
10, 12	250, 300	2 eye-bolts on each side of valve
14-36	350-900	none

6 Tighten the nuts in an alternating pattern as follows:

3-inch (75mm)	45-60 ft-lbs (61-81 N•m)
4-24-inch (100-600mm)	75-90 ft-lbs (102-122 N•m)
30-36-inch (750-900mm)	100-120 ft-lbs (135-163 N•m)

WHY USE THE SPACERS:
A T-bolt head normally goes in this place, so the fitting interferes with tightening the nut. The T-head spacer raises the nut to keep it from contacting the fitting when you tighten the nut.

WHY USE THE EYEBOLTS:
The shape of the eyebolt makes it easier to bolt the MJ Connector to certain sizes of wide-bodied valves. When using to connect two fittings, place the eyebolts in any convenient bolt hole location. The eyes do not have to be rodded.