

## SIGMA DOMESTIC THREADED FLANGES



### Features & Advantages:

SIGMA Domestic Threaded Flanges are manufactured of ductile iron as per ASTM A536 Grade 70-50-05 or 60-42-10 with the threads precisely machined on CNC machine meeting the ductile iron pipe thread specification ANSI/AWWA C115/A21.15 of various fabrication industry.

Threaded flanges are HI HUB 125 Lb 250 PSI rated in accordance with ANSI/AWWA C110/A21.10 & ANSI B16.1 providing accurate & consistent threads.

Flange faces are machined and bolt holes drilled providing dimensional consistency.

Sizes offered are from 3" through 16" with drilled or tapped holes for hex bolt.

**SIGMA Domestic Threaded Flanges are certified to meet AIS/BABA requirements on projects.**

Sizes	Item #	
	Plain	Tapped
3	D-DF3-S	D-TDF3-S
4	D-DF4-S	D-TDF4-S
6	D-DF6-S	D-TDF4-S
8	D-DF8-S	D-TDF6-S
10	D-DF10-S	D-TDF10-S
12	D-DF12-D	D-TDF12-S
14	D-DF14-S	D-TDF14-S
16	D-DF16-S	D-TDF16-S

**Large sizes 20" & above are in the process of development and will be available soon.**

**FOR INQUIRIES, PLEASE REACH OUT TO THE RESPECTIVE SIGMA REGIONAL LOCATIONS**

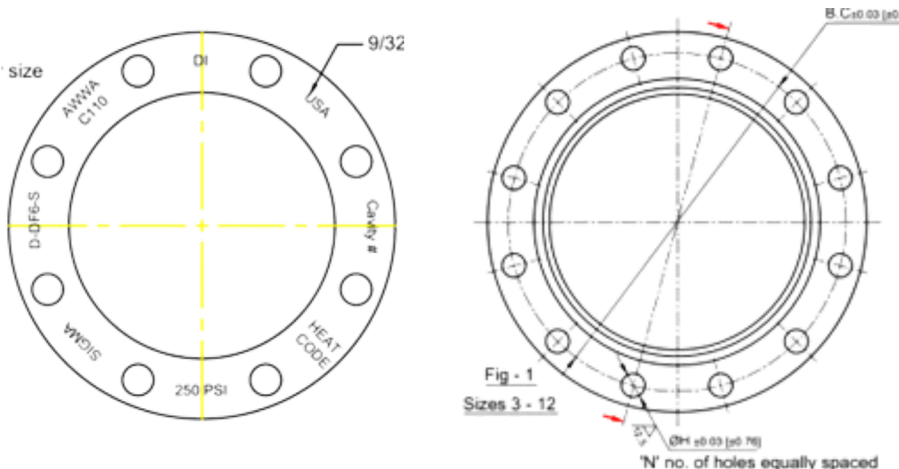

Northeast	CRMCSR@Sigmaco.com 800-999-2550
Southeast	ALXCSR@Sigmaco.com 800-824-4513
Southwest	HTNCSR@Sigmaco.com 800-999-0109
Midwest	CHICSR@Sigmaco.com 312-859-4075
Western	ONTCSR@Sigmaco.com 800-688-6230
Canada East	Tanya@Concordsupply.ca 877-436-3800
Canada West	SBISCHER@Sigmaco.com 312-859-4075
Canada Quebec	JBOUCHER@Repcoc.ca 888-744-6262