

ONE-LOK™ MODEL SSLDH SPLIT WEDGE HARNESS RESTRAINT FOR INSTALLED DUCTILE IRON PIPE

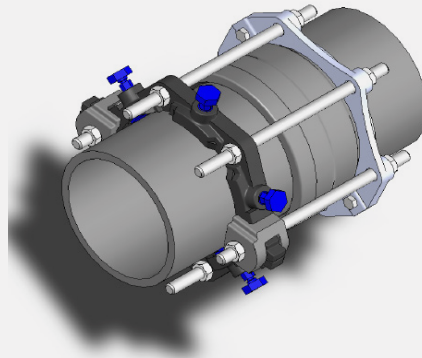
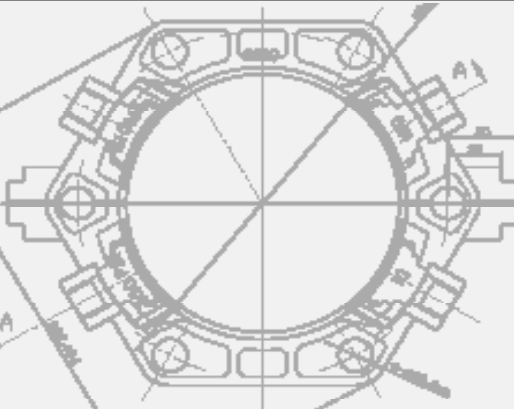

PRODUCT SPECIFICATIONS

- MATERIAL:**
- Gland body, wedge inserts, break-off top actuating bolts, side clamping brackets and split back-up ring are manufactured of high strength ductile iron in accordance with ASTM A536, Grade 65-45-12.
 - Wedge inserts are heat-treated to a hardness of 370 BHN minimum.
- SIZE RANGE:**
- 4" through 42"
- DIMENSION:**
- Conform to ANSI/AWWA C111/A21.11, ANSI/AWWA C110/A21.11, ANSI/AWWA C153/A21.53, ANSI/AWWA C151/A21.51 & ANSI/AWWA C150/A21.50 standards.
- PRESSURE RATINGS:**
- 350 psi on 4"-8", 300 psi on 10"-16", 250 psi on 18"-36" and 200 psi on 42"
- COATING:**
- Asphaltic black enamel
 - Electro-deposition "CORRSAFE™" available upon request. For further information, please refer to our CORRSAFE Product Information sheet at <http://www.sigmaco.com/pipe-restraint-product-coatings-linings/>
- DEFLECTION:**
- 5° for 4"-12", 2° for 14"-16", 1-1/2° for 18"-24" and 1° for 30"-42"
- TRACEABILITY:**
- Gland body, wedge inserts, break-off top actuating bolts, side clamping brackets and split back-up ring are individually cast with exact heat code information.
- INSTALLATION:**
- In accordance with manufacturer's recommendation and applicable AWWA standards.

Note: This product is not designed to be used on plain end fittings.