

PV-LOK™ MODEL PVM SERRATED RESTRAINT FOR DUCTILE IRON FITTING & IPS OD PVC PIPE

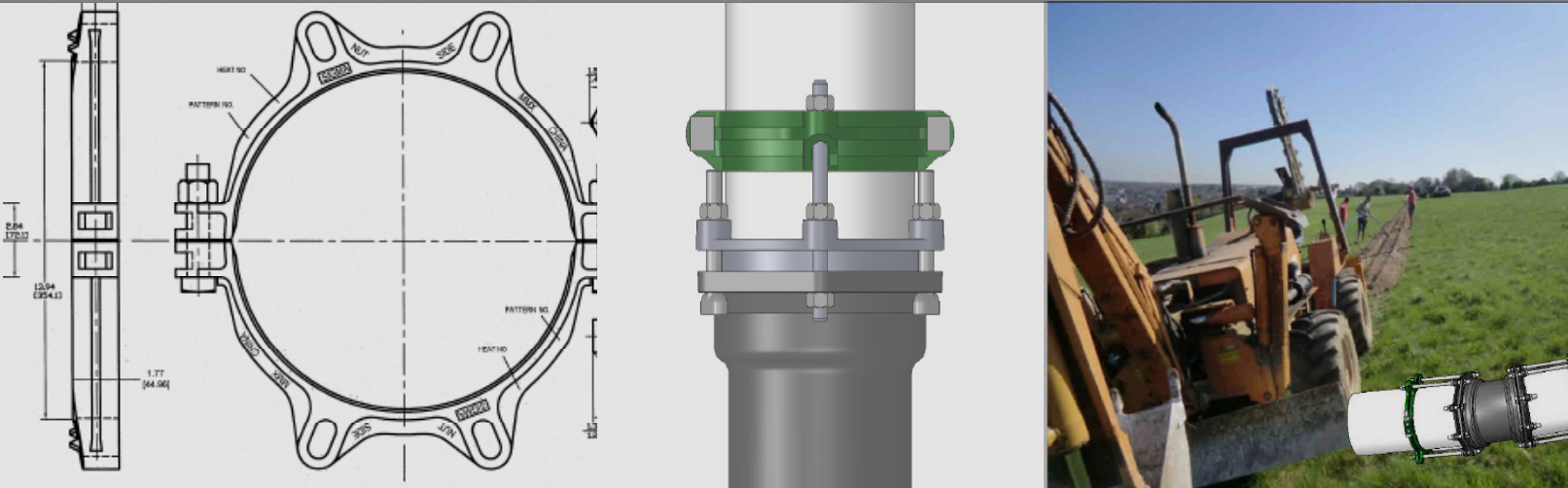

PRODUCT SPECIFICATIONS

- MATERIAL:**
- Machine-serrated clamping ring is manufactured of high strength ductile iron in accordance with ASTM A536, Grade 65-45-12.
 - Side clamping bolts and hex nuts are manufactured of high strength steel in accordance with ASTM A449 and zinc-plated to B663, Type III Sec.1 for corrosion resistance.
- SIZE RANGE:**
- 2" through 12"
- DIMENSION:**
- Conform to ANSI/AWWA C110/A21.11, ANSI/AWWA C153/A 21.53 & ASTM D2241 standards.
- PRESSURE RATINGS:**
- Equal to the water working pressure rating of the pipe upon which it is installed with a minimum 2:1 factor of safety.
- COATING:**
- Green Alkyd Paint
- DEFLECTION:**
- 5° on 3"-12"
- TRACEABILITY:**
- Machine-serrated clamping rings are individually cast with exact heat code information.
- INSTALLATION:**
- In accordance with manufacturer's recommendation and applicable ASTM D2241 PVC pipe standards.

Note: This product is not designed to be used on plain end fittings.